

AL12-F60

INSTALLATION INSTRUCTIONS

WARRANTY

Plane Power, Ltd. warrants its alternators and voltage regulators for a two-year period from date of purchase to be in good working order and free of material defects. Plane Power, Ltd. retains the right to rebuild or replace any alternator or voltage regulator if it fails under the terms of this warranty and *only* if the customer's original alternator or voltage regulator is sent to Plane Power for evaluation, along with a dated copy of the sales receipt. This alternator or voltage regulator must be shipped directly to Plane Power per instructions found in this warranty agreement at the customer's expense for warranty evaluation.

If the alternator or voltage regulator is found to have failed under the terms of this warranty, Plane Power will take the appropriate action of either rebuilding or replacing the alternator or voltage regulator. Customers will be responsible for any additional expedited shipping charges. Plane Power, Ltd. reserves the right to insure all alternators and voltage regulators for loss or damage during shipping directly to the customer.

Plane Power, Ltd. makes no warranty as to suitability of its products for the intended application.

To be considered eligible for warranty consideration, **DO NOT PURCHASE A REPLACEMENT ALTERNATOR OR VOLTAGE REGULATOR FROM A DEALER.** Plane Power, Ltd. will not at any time offer a form of a warranty credit for replacement alternators or voltage regulators purchased through a dealer. All warranty claims must be handled directly by Plane Power, Ltd.

If you suspect an alternator or voltage regulator to be defective and in need of service, call Plane Power, Ltd. at 877-934-5700 for a return authorization number.

Alternators and voltage regulators returned to the factory via UPS with the valid return authorization number will usually be rebuilt or replaced the same day as received. However, other carriers and/or circumstances may increase the turnaround to 1-2 days.

Warranty Details

Plane Power, Ltd. warrants its alternators and voltage regulators to be free from defects in material and workmanship under normal use and operation for a period of two years from date of purchase. Plane Power, Ltd. cannot and never will warrant damage to non-alternator or voltage regulator components or related expenses including labor, inconvenience, transportation or loss of business due to any alternator failure.

Plane Power, Ltd. warranty is *void* if:

- An alternator or voltage regulator is improperly installed.
- An alternator or voltage regulator is used for the wrong application.
- Customer tries to service the alternator or voltage regulator in the field by removing or replacing any of the components not specifically instructed and/or supplied by Plane Power, Ltd.
- The alternator or voltage regulator is determined to have failed by application of voltage in excess of the amount specified on the data plate.
- The alternator or voltage regulator is damaged by impact, shock or excessive abuse, (i.e. dents, large scratches, bent components) actual physical evidence not in conjunction with defective components, design or workmanship.

NOTE: ON LYCOMING INSTALLATION (EXCEPT O-320-H2AD), SAFETY WIRE TENSION ARM BOLTS MS20074 - 05 - 06 & AN5H-5A. ON LYCOMING O-320-H2AD INSTALLATION, SAFETY WIRE TENSION ARM BOLTS MS20074-05-12 & AN5H-5A. ON CONTINENTAL INSTALLATION, SAFETY WIRE TENSION ARM BOLTS AN5H-5A & MS2007 - 05 - 12. FOR CONTINENTAL TURBO INSTALLATION, SAFETY WIRE TENSION ARM BOLT AN5H-13A. USE .032" SAFETY WIRE.

REVISIONS			
LTR.	DESCRIPTION	DATE	APR.
G	ADDED CONTINENTAL ALTERNATOR INSTALLATION AL12-F60C	6/06/06	SJK
H	CLARIFIED MODEL NUMBERS AND CORRECTED TYPO	11/15/06	SJK
J	ADDED 10-1012, REMOVED MS20074-05-07, AND UPDATED NOTE	9/14/07	SJK
K	UPDATED DRAWING TO SHOW INSTALLATION VIEW FOR AL12-F60C	1/08/08	SJK
L	UPDATED VIEW AND ADDED NOTE	6/18/08	SJK

MODEL: AL12 - F60C (FOR CONTINENTAL INSTALLATION)

MODEL: AL12 - F60 (FOR LYCOMING INSTALLATION)

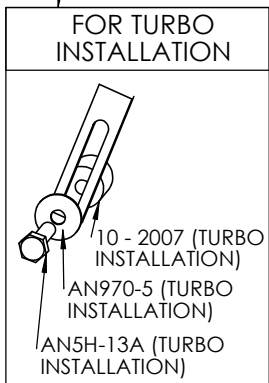
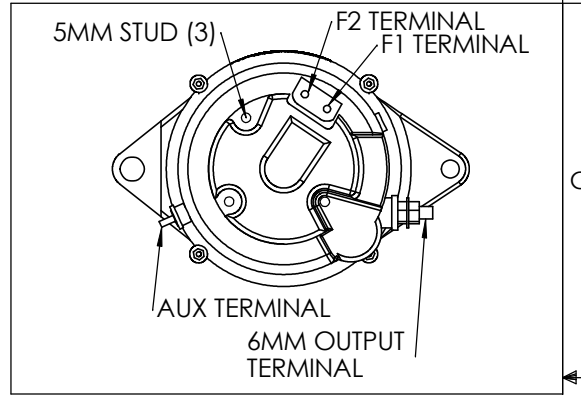
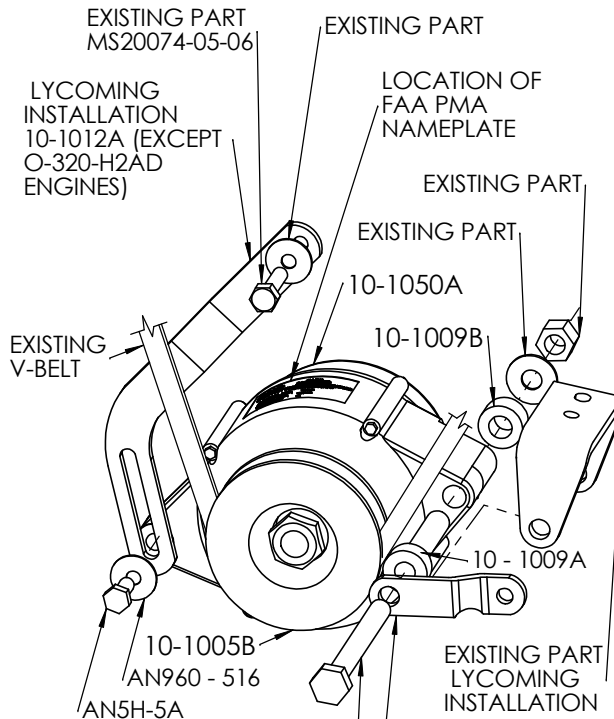
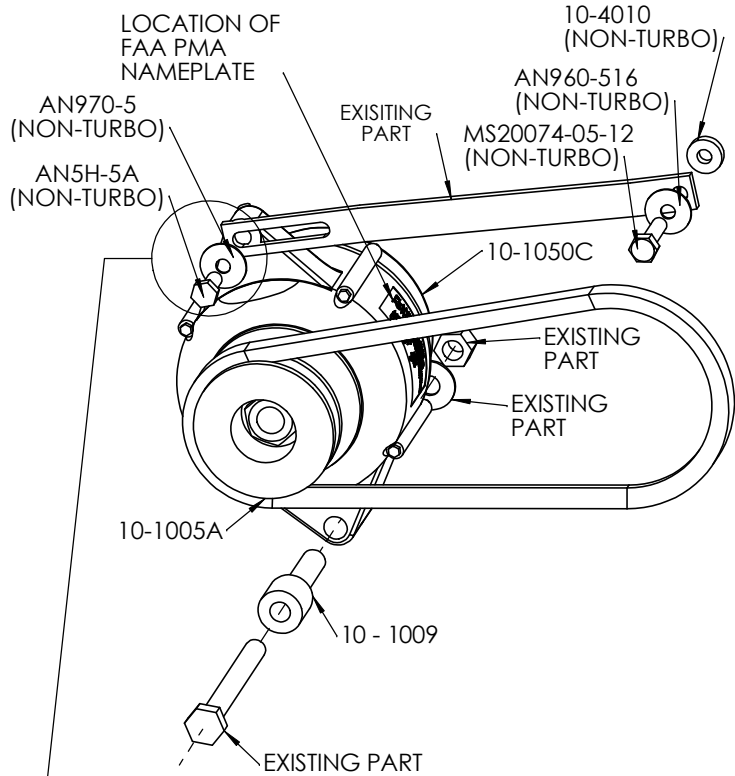

2.5

Plane Power
FAA PMA
PLANE POWER, LTD.
For eligibility see
www.plane-power.com/catalog
or call 1-877-934-5700

MODEL NO. AL12-F60C

SERIAL NO. 2V-YWWSN

VOLTAGE 12

1.3

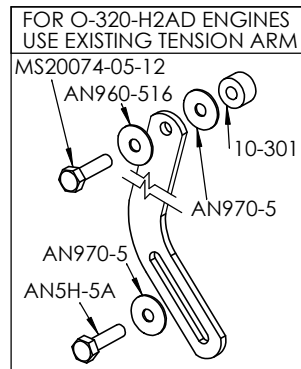

2.5

Plane Power
FAA PMA
PLANE POWER, LTD.
For eligibility see
www.plane-power.com/catalog
or call 1-877-934-5700

MODEL NO. AL12-F60

SERIAL NO. 2V-YWWSN

VOLTAGE 12

1.3

FAA PMA nameplate material to be adhesive backed Silver Polyester with permanent thermal print

PLANE POWER, LTD.
GRANBURY, TEXAS

AL12 - F60/AL12 - F60C
INSTALLATION INSTRUCTIONS

DRAWN BY: B. JOWERS	DATE: 2/15/05
MATERIALS:	DWG. NO. 10 - 4001 REV. L

INSTALLATION AND CONTINUED AIRWORTHINESS INSTRUCTIONS ON REVERSE SIDE

Part No. 10-4001

Installation Instructions

1. Disconnect aircraft battery.
2. Install alternator per included drawing.
3. Refer to appropriate engine and airframe service manuals for belt tension and bolt torques.
4. Install battery wire with MS25171-2S terminal nipple on 6mm output terminal and torque to 50 in. lb.
5. Install ground wire to any of the three 5mm studs on rear of alternator and torque to 35 in. lb.
6. Install field wire with MS25171-1S terminal nipple to F1 terminal on rear of alternator and torque to 20 in. lb.
7. NOTE: F2 terminal to remain grounded with ground strap UNLESS aircraft voltage regulator is a type "A" regulator using a 2-wire field circuit, in this case remove and discard ground strap from F2 terminal and connect wiring from voltage regulator to F1 and F2 terminals, torque to 20 in. lb.
8. If aircraft is equipped with an "alternator out light" circuit, connect that wire to the AUX terminal and torque to 20 in. lbs. Other wise leave AUX terminal open.
9. Reconnect aircraft battery.
10. Start aircraft and check alternator output for proper operation.

Instructions For Continued Airworthiness

Annual / 100 hour inspections:

1. Remove drive belt and turn alternator rotor to check condition of bearings for abnormal noise or roughness.

5 year or 1,000 hour intervals:

1. Repeat: Annual / 100 hour inspection.
2. Remove field brush assembly and inspect brushes for excess wear. Replace brush assembly if brushes extend less than .250" from edge of brush holder case.

Weight and Balance/Equipment List Revision

Name: _____ Date: _____
 Aircraft Make/Type: _____ Model#: _____
 Registration#: _____ Serial#: _____

Previous Date: _____ Weight: _____ Arm: _____ Moment: _____

Equipment List	In	Out	Weight	Arm	Moment:
P/N Plane Power Alternator S/N					
1.	X				
2.					
3.					
4.					

Aircraft Empty Weight: _____
 Arm: _____
 Moment _____
 Gross Weight _____
 Useful Load _____

Signature _____
 Authorization _____

Note: Weight and balance must be completed and attached to pilot's operating handbook.

Plane Power Ltd Alternator weights

	AL12-C60	AL12-P70 (70amp)	AL12-P70 (60amp)	AL24-P70	AL12-F60	AL12-F60C	AL24-F60	AL24-F60C
Installed	10.9 lbs.	10.1 lbs.	10.1 lbs.	10.1 lbs.	9.9 lbs.	9.9 lbs.	9.9 lbs.	9.9 lbs.
Removed	13.9 lbs.	12.7 lbs.	11.4 lbs.	12.7 lbs.	10.8 lbs.	10.8 lbs.	10.8 lbs.	10.8 lbs.

Your kit should include the following parts. Please check to insure that all parts are included before installing. If any parts are missing please contact Plane Power at 1-877-934-5700.

- | | | |
|----------|---|----------------------------|
| 1 | 10-1009A | Pivot Hole Spacer Bushing |
| 1 | 10-1009B | Pivot Hole Spacer Bushing |
| 1 | 10-3011 | Tension Arm Spacer at Case |
| 1 | 10-1012A | Tension Arm |
| 1 | AN5H-5A | Bolt |
| 1 | MS20074-05-12 | Bolt |
| 2 | AN970-5 | Washer |
| 2 | AN960-516 | Flat Washer |
| 1 | Installation Drawing 10-4001 or 10-7001 | |
| 1 | Weight & Balance Form | |
| 1 | Promo Sticker | |